

Technical Documentation



0586-DOC-M2M-ASTRO

Astronode S+ Datasheet

For feedback or questions: support@astrocast.com



Document history

Issue/rev.	Date	Modifications
1/0	26.01.2022	First Release
0/1	09.11.2021	Initial preliminary version

Reference documents

Document name	Document number
Astronode S Datasheet	0532
Astronode Patch Antenna Datasheet & Integration Guide	0534
APN Astronode S Low Energy Guidelines	0559
REACH and RoHS Declaration	0627
WP Product homologation with embedded Astronode S	0628
WP Data handling and security	0619
RED Declaration of conformity	0646

In this document



This is an information



This is a warning

1 Astronode S+ overview

1.1 Key features

- Worldwide data communication over satellite:
 - o Encrypted data communication
 - o 2-level 256-bit AES with unique device key
 - o L-band frequency
- Built-in RTC
- Low power communication @ 3.3V:
 - o TX: 76 mA
 - o RX: 48 mA
- Low power mode @ 3.3V:
 - o Sleep mode: 3.9 uA
 - o Deep sleep mode: 320 nA
- Power supply: 3.3 V or 5.0 V
- User UART or RS232 interface
- Built-in Astronode Patch Antenna
- Small form factor:
 - o Size: 65 x 70 mm +/- 0.1
 - o Weight 38.8 gr +/- 0.2
- Operating temperature: -20°C to 70°C

1.2 Certifications and approvals

- CE, FCC ID 2A269-01001
- RoHS, REACH

1.3 Typical use cases

- Maritime
 - o Container tracking
 - o Fishing buoys
- Agriculture
 - o Fuel management
 - o Precision farming
- Environment
 - o Weather data
 - o Flow monitoring

1.4 Description

The Astronode S+ is a ready to install satellite communication device, based on an Astronode S and an Astronode Patch Antenna. It connects to your application via the full Astronode S digital interface or via RS232, both available on the industrial grade board-to-cable connector. It both integrates new applications as well as retrofits applications in the field for bidirectional satellite communication. The device comes in a small form factor, fully integrated and certified CE and FCC.

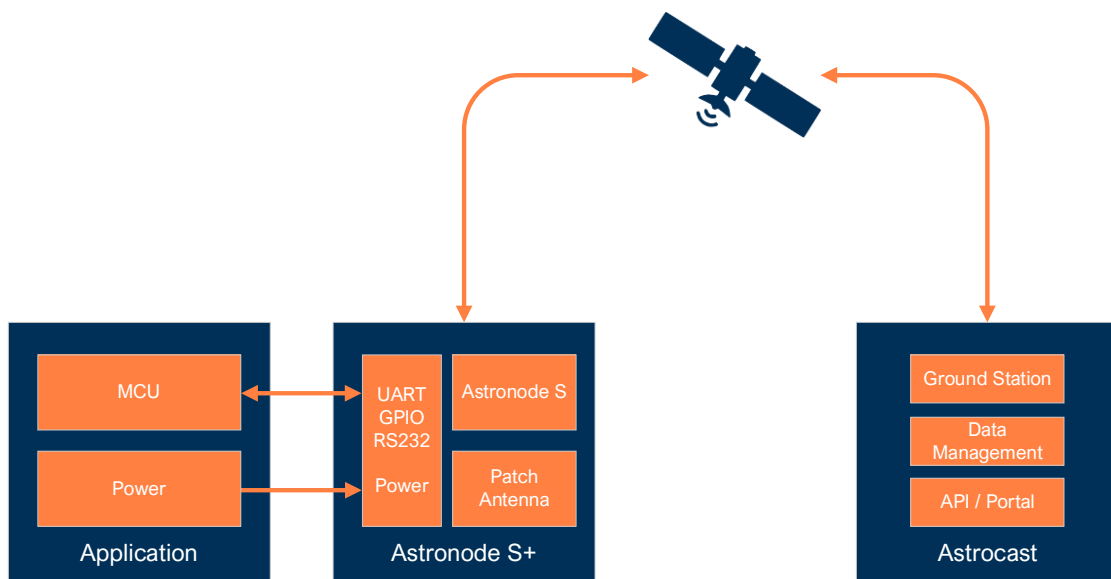

2 Product image

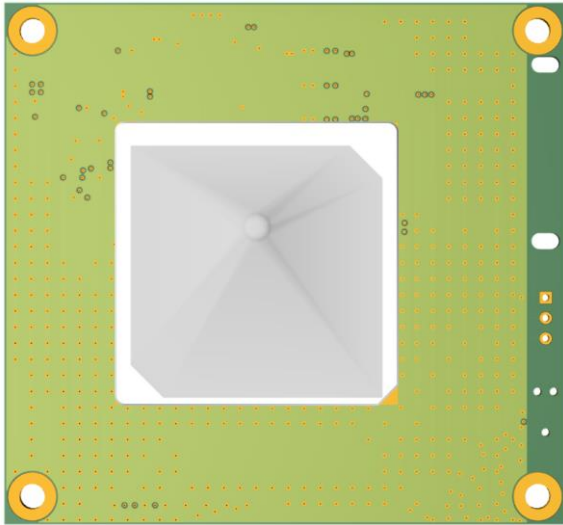

Figure 1 - Top with antenna

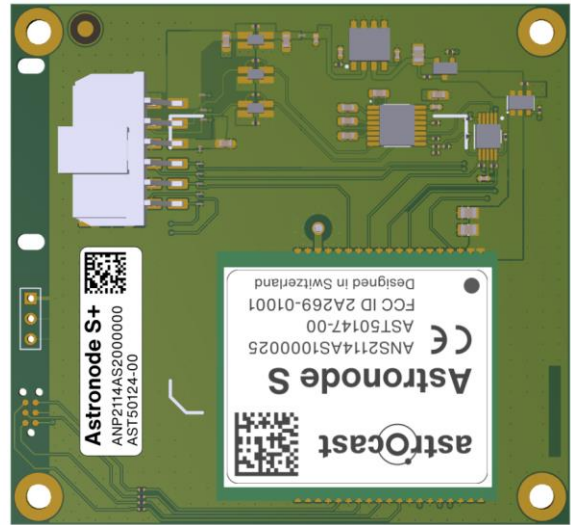
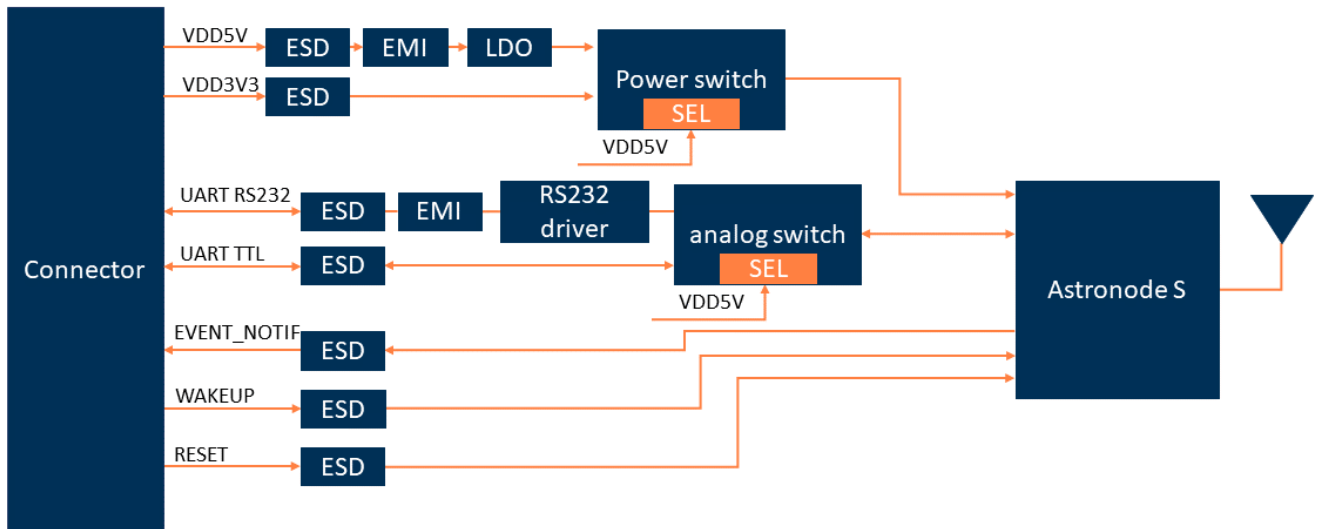

Figure 2 - Bot with Astronode S and connector

3 Block diagram



4 Table of Content

1	Astronode S+ overview	3
1.1	<i>Key features</i>	3
1.2	<i>Certifications and approvals</i>	3
1.3	<i>Typical use cases</i>	3
1.4	<i>Description</i>	3
2	Product image	4
3	Block diagram	4
4	Table of Content	5
5	Connector pinout	6
6	Electrical characteristics	7
6.1	<i>Absolute maximum rating</i>	7
6.2	<i>Operating conditions</i>	8
7	Antenna characteristics	11
8	Detailed description	11
8.1	<i>Serial interface</i>	11
8.2	<i>Connectivity</i>	12
8.3	<i>GPIOs</i>	12
9	Installation guidelines	13
9.1	<i>Connector strain relief</i>	13
9.2	<i>Environment</i>	13
9.3	<i>Orientation</i>	14
9.4	<i>Wiring and cable length</i>	14
9.5	<i>Cable assembly</i>	15
10	Mechanical drawing	16
11	ESD precautions	16
12	Ordering codes	16
13	Packaging	17
14	Product labelling	17
14.1	<i>Serial Number format</i>	17
15	Certifications	18
15.1	<i>CE</i>	18
15.2	<i>FCC</i>	18
15.3	<i>Distance to human body</i>	18
15.4	<i>Applicable standards</i>	18

5 Connector pinout

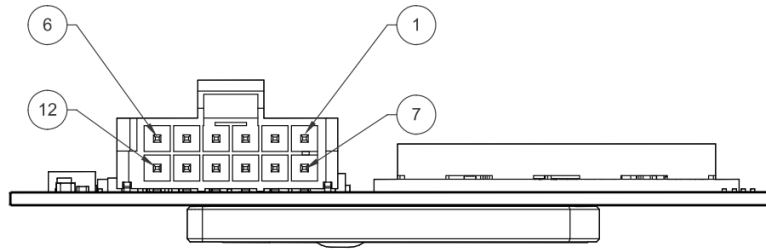

Figure 3 - Pin definition - Side view

6	5	4	3	2	1
VDD5V	RXD_RS232	VDD3V3	RXD_TTL	RESET	EVENT_NOTIF
12	11	10	9	8	7
GND_RS232	TXD_RS232	GND	TXD_TTL	GND	WAKEUP

Table 1 - Pinout table

Pin name	Pin number	I/O type	Description
VDD3V3	4	Power	3.3V Power supply if the TTL interface is used
VDD5V	6	Power	5V Power supply if the RS232 interface is used
TXD_RS232	11	Output	TX UART of the Astronode S+, RS232 level
RXD_RS232	5	Input	RX UART of the Astronode S+, RS232 level
TXD_TTL	9	Output	TX UART of the Astronode S+, TTL level
RXD_TTL	3	Input	RX UART of the Astronode S+, TTL level
EVENT_NOTIF	1	Output	Indicates an event. Internal pull-down of 1Mohm
RESET	2	Input	Reset of the Astronode S+. Active on rising edge. Leave unconnected if unused.
WAKEUP	7	Input	Wakeups the Astronode S+ from low power mode. Internal pull-down of 1Mohm.
GND	8	Power	Ground
GND	10	Power	Ground
GND_RS232	12	Power	Ground for RS232 interface

Table 2 - Pin table

6 Electrical characteristics

6.1 Absolute maximum rating

At GND = 0V and all voltages are referred to the ground (unless otherwise noted)

Symbol	Ratings	Min	Max	Unit
Tstg	Storage temperature.	-40	85	°C
TTL				
VDD3V3	3.3V supply voltage.	-0.3	4.0	V
I _{dd3V3}	Main supply current	-	100	mA
V _{i_wakeup}	Input voltage for WAKEUP pin	-0.3	4.0	V
V _{i_rst}	Input voltage for RST pin.	-6.3	6.3	V
I _{o_ttl}	Output current from EVENT_NOTIF and TXD_TTL pins.	-25	40	mA
RS232				
VDD5V	5V supply voltage.	-0.3	7	V
I _{dd5V}	Main supply current	-	110	mA
V _{i_rs232}	Input voltage for RXD_RS232 pin.	-30	30	V
I _{o_rs232}	Output current from RXD_RS232 pin	-10	10	mA

Table 3 - Absolute maximum rating



Stress beyond values listed under Absolute Maximum ratings may cause permanent damage to the device.

These are stress ratings only, which do not imply functional operation of the device at these or any other condition beyond those indicated under operating conditions. Exposure to absolute maximum rated conditions for extended periods of time may affect device reliability.

6.2 Operating conditions

At GND = 0V and all voltages are referred to ground (unless otherwise noted).

Unless otherwise specified, typical data are based on $T_a = 25^{\circ}\text{C}$, $V_{DD3V3} = 3.3\text{V}$ and $V_{DD5V} = 5\text{V}$. The minimum and maximum values are guaranteed in the worst conditions of ambient temperature and supply voltage.

6.2.1 General operating conditions

Symbol	Parameter	Conditions	Min	Typ	Max	Unit
P_{out}	EIRP Power output	-	-	-	20	dBm
$T_{opr}(2)$	Operating temperature	-	-20	-	70	$^{\circ}\text{C}$
TTL						
$V_{DD3V3}(1)$	3V3 supply voltage	-	3.14	3.3	3.47	V
V_{i_wakeup}	Input voltage for WAKEUP pin	-	-0.3	-	$V_{DD3V3}+0.3$	V
V_{i_rst}	Input voltage at RST pin	-	-0.5	-	5.5	V
RS232						
V_{DD5V}	5V supply voltage	-	4.5	5	5.5	V

Table 4 - General operating conditions

(1) performance under evaluation, use typical values.

(2) Performances under extreme conditions are under evaluation.

6.2.2 Reset pin

Symbol	Parameter	Conditions	Min	Typ	Max	Unit
$V_{il}(1)$	Reset input low level voltage.	-	-	-	0.6	V
$V_{ih}(1)$	Reset input high level voltage.	-	0.6	-	1.5	V

Table 5 - RESET pin

(1) Not measured, to be evaluated.

6.2.3 I/O characteristics

Characteristics for I/Os except for the RESET pin and RS232 interface:

Symbol	Parameter	Conditions	Min	Typ	Max	Unit
V_{il}	I/O input low level voltage.	-	-	-	$0.3 \times V_{DD3V3}$	V
V_{ih}	I/O input high level voltage.	-	$0.7 \times V_{DD3V3}$	-	-	V
V_{hys}	Input hysteresis.	-	-	200	-	mV
I_{lkg}	Input leakage current.	-	-	-	+/- 100	nA
V_{ol}	Output low level voltage.	$ I_{i/o} = 8 \text{ mA}$	-	-	0.4	V
V_{oh}	Output high level voltage.	$ I_{i/o} = 8 \text{ mA}$	$V_{DD3V3} - 0.4$	-	-	V

Table 6 - I/O characteristics

6.2.4 RS232 interface

Symbol	Parameter	Conditions	Min	Typ	Max	Unit
Receiver						
V_i	Receiver input voltage.	-	+/-3	-	+/-10	V
V_{it+}	Receiver positive-going input threshold voltage	$T_a = 25^\circ\text{C}$	-	1.7	2.4	V
V_{it-}	Receiver negative-going input threshold voltage	$T_a = 25^\circ\text{C}$	0.8	1.2	-	V
V_{hys}	Input hysteresis voltage	-	0.2	0.5	1	V
I_{lkg}	Input leakage current.	-	-	-	+/- 100	nA
R_i	Receiver input resistance	$T_a = 25^\circ\text{C}$	3	5	7	k Ω
Driver						
V_{oh}	High level output voltage	$R_L = 3 \text{ k}\Omega$ to GND	5	7	-	V
V_{oL}	Low level output voltage (1)	$R_L = 3 \text{ k}\Omega$ to GND	-	-7	-5	V
R_o	Output resistance	$V_o = +/-2 \text{ V}$	300	-	-	Ω
I_{os}	Short-circuit output current	$V_o = 0 \text{ V}$, $V_{DD5V} = 5.5\text{V}$	-	+/-10	-	mA

Table 7 - RS232 interface characteristics

(1) The algebraic convention, in which the least-positive (most negative) value is designated minimum, is used in this datasheet for logic voltage levels only.

6.2.5 RS232 interface switching characteristics

Symbol	Parameter	Conditions	Min	Typ	Max	Unit
Receiver						
$T_{PLH(R)}$	Receiver propagation delay time, low to high level output	$C_L = 50 \text{ pF}$	-	500	-	ns
$T_{PHL(R)}$	Receiver propagation delay time, high to low level output	$C_L = 50 \text{ pF}$	-	500	-	ns
Driver						
SR	Driver slew rate	$R_L = 3 \text{ k}\Omega \text{ to } 7 \text{ k}\Omega$	-	-	30	V/us
SR(t)	Driver transition region slew rate	$R_L = 3 \text{ k}\Omega$ $C_L = 2.5 \text{ nF}$	-	3	-	V/us
DR	Data rate	-	-	250	-	Kbits/s

Table 8 - RS232 interface switching characteristics

6.2.6 Current consumption

Measurements done @ $T_a = 25^\circ\text{C}$

Symbol	Parameter	Conditions	Min	Typ	Max	Unit
$I_{tx}(1)$	TX current.	$VDD3V3 = 3.3V$	-	76	-	mA
		$VDD5V = 5V$	-	80.3	-	mA
$I_{rx}(1)$	RX current.	$VDD3V3 = 3.3V$	-	48	-	mA
		$VDD5V = 5V$	-	52.3	-	mA
$I_{active}(1)$	Active state current	$VDD3V3 = 3.3V$	-	7.6	-	mA
		$VDD5V = 5V$	-	11.9	-	mA
$I_{idle}(1)$	Idle state current	$VDD3V3 = 3.3V$	-	3.7	-	mA
		$VDD5V = 5V$	-	8	-	mA
$I_s(1)$	Sleep mode current.	$VDD3V3 = 3.3V$	-	3.9	-	μA
		$VDD5V = 5V$	-	4.3	-	mA
$I_{ds}(1)$	Deep sleep mode current.	$VDD3V3 = 3.3V$	-	320	-	nA
		$VDD5V = 5V$	-	4.3	-	mA

Table 9 - Current consumption

(1) Disparity measurement ongoing

7 Antenna characteristics



See *0534 Astronode Patch Antenna Datasheet & Integration Guide* for any details about the built-in antenna

8 Detailed description

8.1 Serial interface

The Astronode S+ has two serial communication interfaces which control the same Astronode S radio module. Each interface can only be used when they are supplied by the assigned power input. The RS232 interface is powered by the VDD5V pin and the UART TTL is powered by the VDD3V3 pin.



Only one serial interface can be active at a time, depending on the applied power supply level

One interface can be active at a time, if the Astronode S+ is supplied through VDD3V3, only the UART TLL interface will be available and the RS232 interface will be disabled. In the other case, if the Astronode S+ is supplied through VDD5V, only the RS232 interface will be available and the UART TTL interface will be disabled

If VDD3V3 and the VDD5V are powered at the same time, the VDD5V will be selected and the VDD3V3 will be internally disabled so only the RS232 interface will be active.

The truth table in Table 10 summarizes the active interfaces as a function of the applied supply voltages.

Active interface	VDD3V3 = 0V	VDD3V3 = 3.3V
VDD5V = 0 V	-	UART TTL
VDD5V = 5 V	RS232	RS232

Table 10 - Interface truth table

8.2 Connectivity

There are two groups of signals, one group is RS232/5V compatible and the other group is 3.3V compatible as shown in the Table 11 and Table 12.

8.2.1 RS232 interface and 5V compatible signals

6	5			2	
VDD5V	RXD_RS232			RESET	
12	11				
GND_RS232	TXD_RS232				

Table 11 – Connector with RS232 and 5V compatible signals

The VDD5V, RXD_RS232 and TXD_RS232 signals must use the GND_RS232 as ground reference. This is due to the EMI filters present on the Astronode S+.



If the GND reference is used instead of the GND_RS232, the EMI filters effectiveness will be lost

It's not recommended to connect the GND_RS232 and GND together to keep the EMI filters effective.



Both *EVENT_NOTIF* and *WAKEUP* pins are available in RS232 mode, but with 3.3V logic level

8.2.2 UART TTL interface and 3.3V compatible signals

		4	3	2	1
		VDD3V3	RXD_TTL	RESET	EVENT_NOTIF
		10	9	8	7
		GND	TXD_TTL	GND	WAKEUP

Table 12 – Connector with TTL interface and 3.3V compatible signals

All signals from Table 12 must use the GND as reference.

As it's shown in Table 11 and Table 12, the RESET pin is compatible with both 3.3V and 5V. The Reset signal can either use GND or GND_RS232 as reference.

8.3 GPIOs



For UART protocol, sleep modes, event interrupt, reset function, see *0532 Astronode S Datasheet* (in complement to Chapter 8)

9 Installation guidelines

9.1 Connector strain relief

If the connected wires are exposed to forces or vibrations during handling, installation or use of the application, the female connector can be strain relieved. It may be secured to the Astronode S+ by means of a 2.5mm wide cable tie running through the two slots available for this purpose.

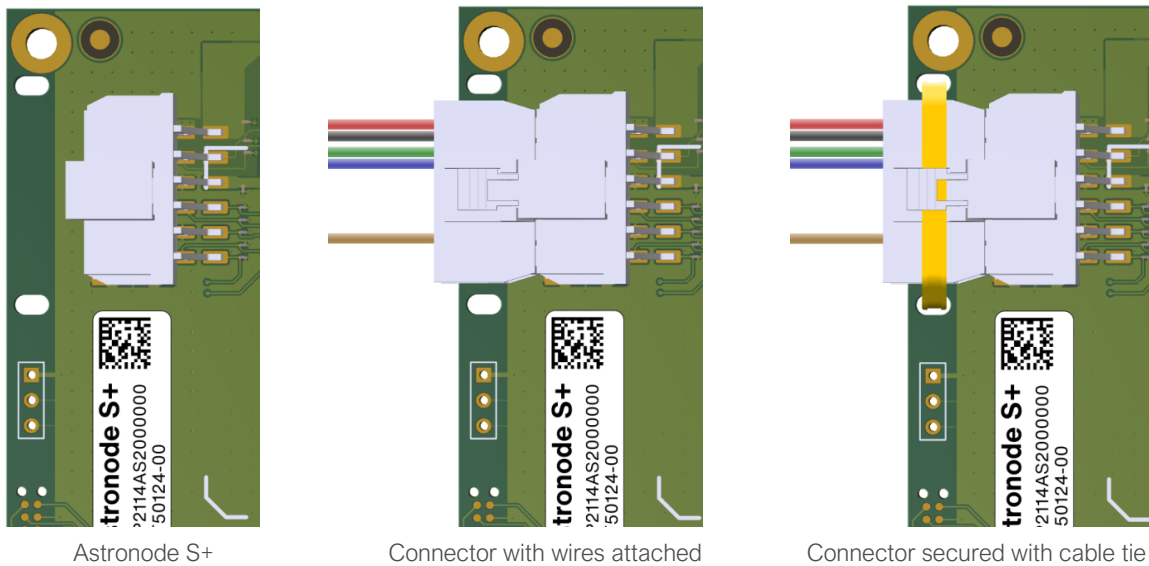

Figure 4 Connector strain relief



The male Molex connector on the Astronode S+ is surface mounted and not intended to absorb forces applied by the attached cable. It may break when used without strain relief

9.2 Environment

Appropriate environmental protection must be provided for operation such as a vented IP6X housing or comparable. The Astronode S+ should be protected from humidity and extreme temperatures, see Chapter 6.2 for operating conditions.

Carefully select the plastic material of the housing to prevent degradation of the RF link quality between the Astronode S+ antenna and the satellite. Avoid any metallic parts above or next to the Astronode S+ installation.



See *0559 APN Astronode S Low Energy Guidelines* for all factors having a potential impact on the performance of the service

9.3 Orientation

It is highly recommended to always install the Astronode S+ horizontally and with free view to the sky, with the patch antenna pointing towards the sky.

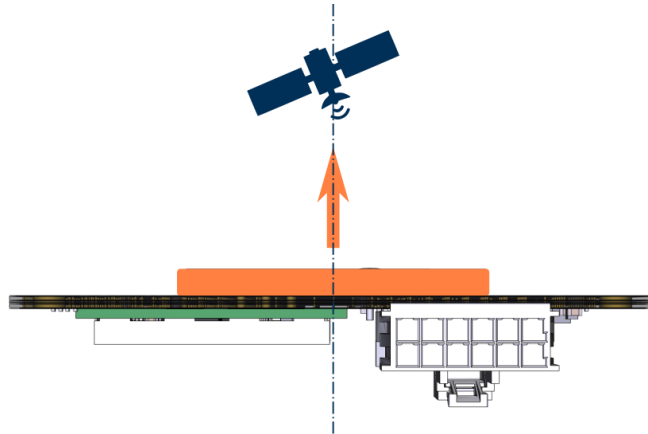
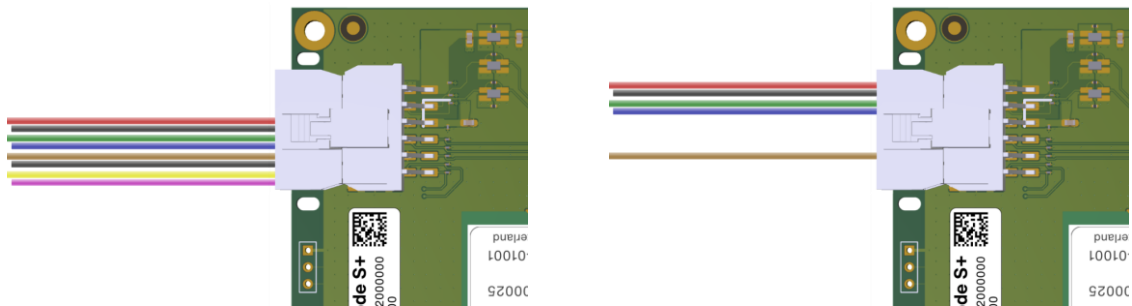

Figure 5 Antenna pointing towards sky, horizontal orientation

9.4 Wiring and cable length

The Astronode S+ features a single Molex Nano-Fit connector providing all interface signals. By using either one of the interface modes and supply voltages, only the corresponding signals need to be wired:



UART interface, see Chapter 8.2.2

RS232 interface, see Chapter 8.2.1

Figure 6 Wiring

The maximum cable length for *TXD_RS232* and *RXD_RS232* according to the RS232 protocol is 15m. In any case, carefully evaluate the maximum length which works in the final application and environment.

There is no recommended maximum length for power supply over the *VDD5V* or *VDD3V3* line. However, wires and power supply must be carefully selected or designed to meet operating conditions and operating ratings for the Astronode S+ (See Chapters 6.2).



The use of a local power supply is recommended when connecting the Astronode S+ over long distances – Avoiding long power supply lines

9.5 Cable assembly

Only use the parts presented in Table 13 for the cabling between the Astronode S+ and the application. The crimped strands may optionally be secured with a Terminal Position Assurance (TPA) retainer.

Appropriate coating of the crimp terminals must be determined for each specific application.

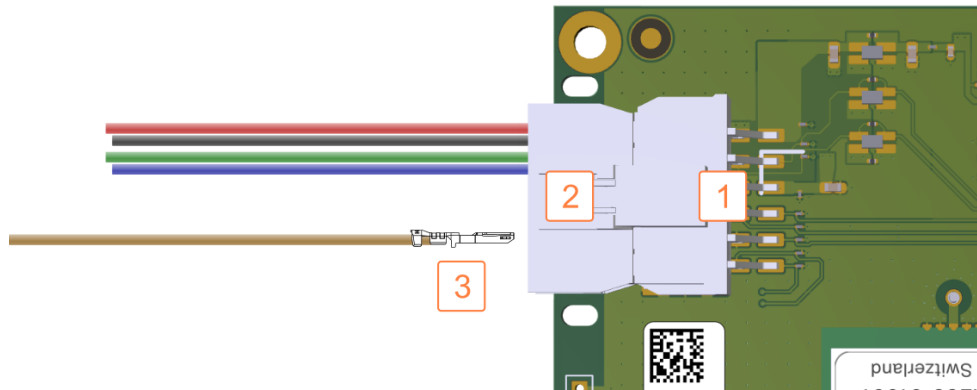

	Part	Manufacturer	Manufacturer Number
1	Nano-Fit Header SMT Male (mounted)	Molex	1054051212
2	Nano-Fit Receptacle Housing	Molex	1053081212
3	Nano-Fit Crimp Terminal Female	Molex	105300 Series
-	Nano-Fit TPA (Optional)	Molex	105325 Series
-	Nano-Fit Pre-Crimped leads 15 cm (Gold)	Molex	797582129
-	Nano-Fit Pre-Crimped leads 30 cm (Gold)	Molex	797582130
-	Nano-Fit Pre-Crimped leads 15 cm (Tin)	Molex	797582139
-	Nano-Fit Pre-Crimped leads 30 cm (Tin)	Molex	797582140

Table 13 - Cable assembly parts

10 Mechanical drawing

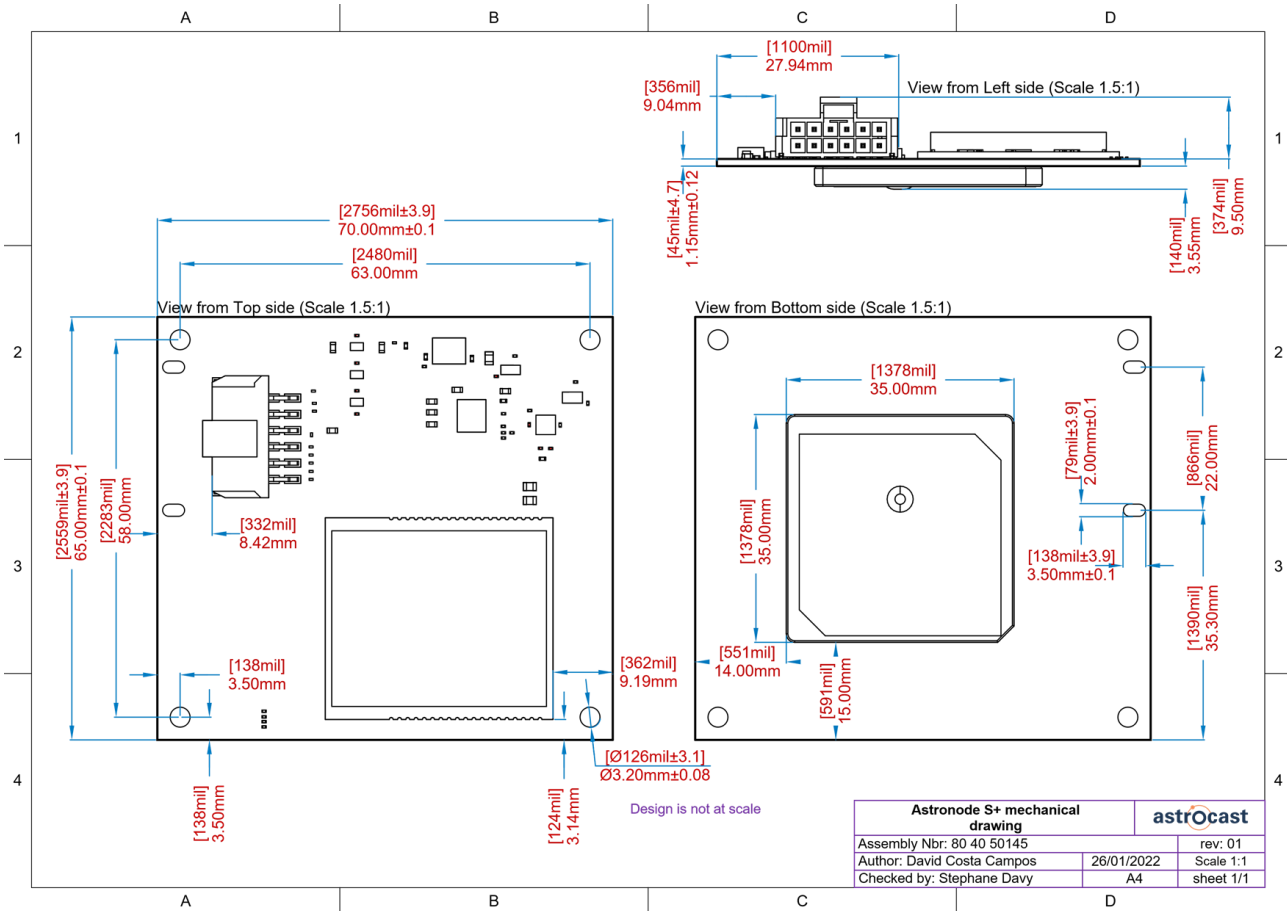

Figure 7 - Astronode S+ mechanical drawing

11 ESD precautions

Astrocast recommends the product to be handled with appropriate precautions. Failure to observe proper handling and installation procedures can cause damage.

The Astronode S+ contains exposed electronic circuitry which is electrostatic sensitive. Handling the Astronode S+ without proper ESD protection may destroy or damage it permanently

12 Ordering codes

Item Number	State	Description
AST50124-00	ACTIVE	Astronode S+

13 Packaging

The Astronode S+ is delivered in a single item, ESD air-bubble-bag packaging with the following package label:



Figure 8 Package label

1	Serial Number in text and Data Matrix format
2	Item Number in text and Data Matrix format

14 Product labelling

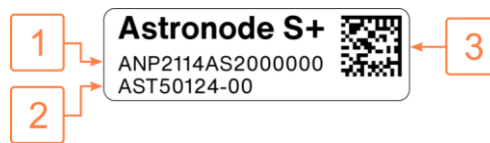

Figure 9 - Product label

1	Serial Number
2	Item Number
3	Serial Number in Data Matrix format

14.1 Serial Number format



1	Production date: last two digits of the year
2	Production date: week number of the year
3	Production site
4	Unique identifier

15 Certifications

15.1 CE

The Astronode S+ conforms with essential requirements of the radio Equipment Directive (RED) (2014/53/EU). Please note that the Astronode S+ is not an end-product. It is on the responsibility of the manufacturer to ensure the compliance.

15.2 FCC

The Astronode S+ contains the module Astronode S with the FCC ID **2A269-01001**. Please refer to the document *0532 Astronode S datasheet* for more information.

15.3 Distance to human body

The minimum distance from the Astronode S+ must be above 20cm.

15.4 Applicable standards

In the Table 14, the list of applicable standards is shown

	CE	FCC
EMC	EN 301 489-1 v2.2.3:2019-11 EN 301 489-20 v2.1.1:2019-04	Part 15 B
Radio	EN 301 426 v2.1.2:2016-11	Part 25
Safety	EN 62368-1:2014	-
Health	EN 62311:2008	Part 2.1091

Table 14 - Standards list